

# CV3000 Series

## Characterized Insert Control Valves

The **CV3000 Series** is a v-type control valve for precise control allowing high pressure drop capability with straight-through flow and bubble-tight shut off.

- State-of-the-art modulating ball valve for control offering high capacity with increased rangeability
- The throttling element of the valve is a v-control metal insert located behind the upstream seat. This protects the soft seats from high velocities and ensures bubble-tight shut off when required
- The soft seats and/or the v-style insert can be changed in the field with no need for lapping ball, seats, or insert
- The valve offers metal encapsulated soft seats to prevent cold-flowing under adverse temperature, pressure, or modulating service conditions
- V-Control insert and metal encapsulated seats provide lower operating torque with less hysteresis
- Available in sizes 1/2" through 4" standard port port and 1/4" through 3" full port design
- Materials of construction for the valve or insert include Hastelloy B, Alloy 20, Hastelloy C, Bronze, Monel, Carbon Steel, Stainless Steel, and other special materials such as Duplex, 254 SMO, and Titanium
- A variety of soft seat materials are available including PTFE, Carbon or Stainless filled PTFE, Delrin® or PEEK



# Marwin Valve CV3000 Series – Features

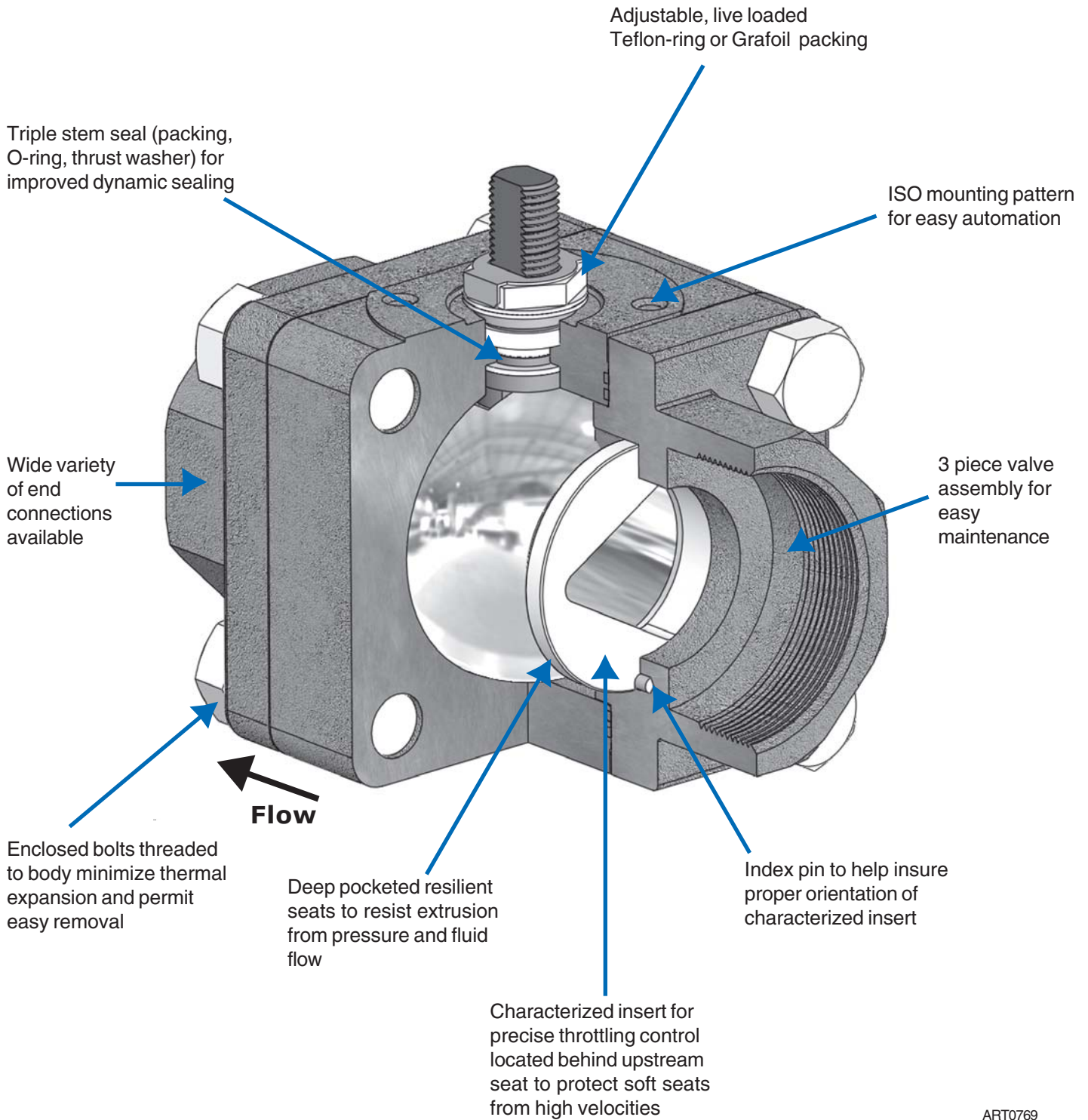

ART0769

## Description

The CV-3000 Series can be fitted with a wide range of v-style inserts for precise throttling control. The inserts are placed in a machined groove in the end cap behind the upstream seat to characterize the flow. The v-style insert is placed on the inlet side of the valve to protect the seat from high velocities, which can occur while controlling flow. The ball sits between two soft seats, ensuring low torque with a bubble-tight shut off. The insert is designed to change flow characteristics of the valve and is offered in different configurations to meet a variety of modulating applications.

The characterized insert control valve gives accurate control through the valve stroke to meet flow conditions. Different insert shapes will affect the flow rate, capacity, and inherent flow curves.

## Operation

The Marwin characterized inserts make throttling control valves that are both forgiving and accommodating. If the valve is located in a process with changing conditions, the characterized insert can be changed to meet the CV and/or the required control characteristics. We offer the option of a full flow insert in the CV3000 valve with additional V-control inserts to be installed later to meet changing flow conditions.

Special flow conditions can be met with optional inserts. An example is a low flow slot insert having a solids removal hole. This type insert provides ideal throttling characteristics which allow solids to move when needed through the larger opening. Linear conditions can be modified by changing the width and/or length of the slot.

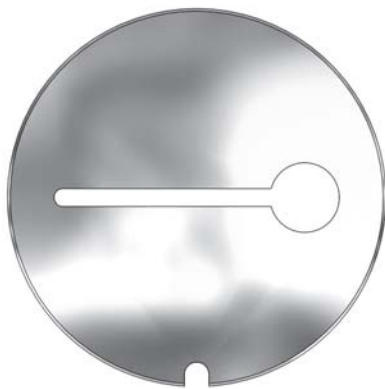

Another example is high flow to low flow by combining larger initial openings with smaller V-shaped final openings. This characterized insert results in smooth stable throttling control, and can be utilized in two stage or dribble control. This provides maximum initial flow and fine control for flow completion.

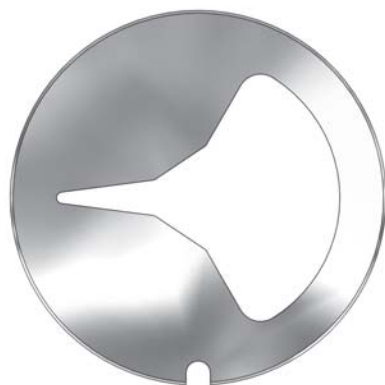

# Marwin Valve CV3000 Series – Dimensions

## CV3000 Series Full Port with UT Series Pneumatic Actuator and 2IQ Positioner

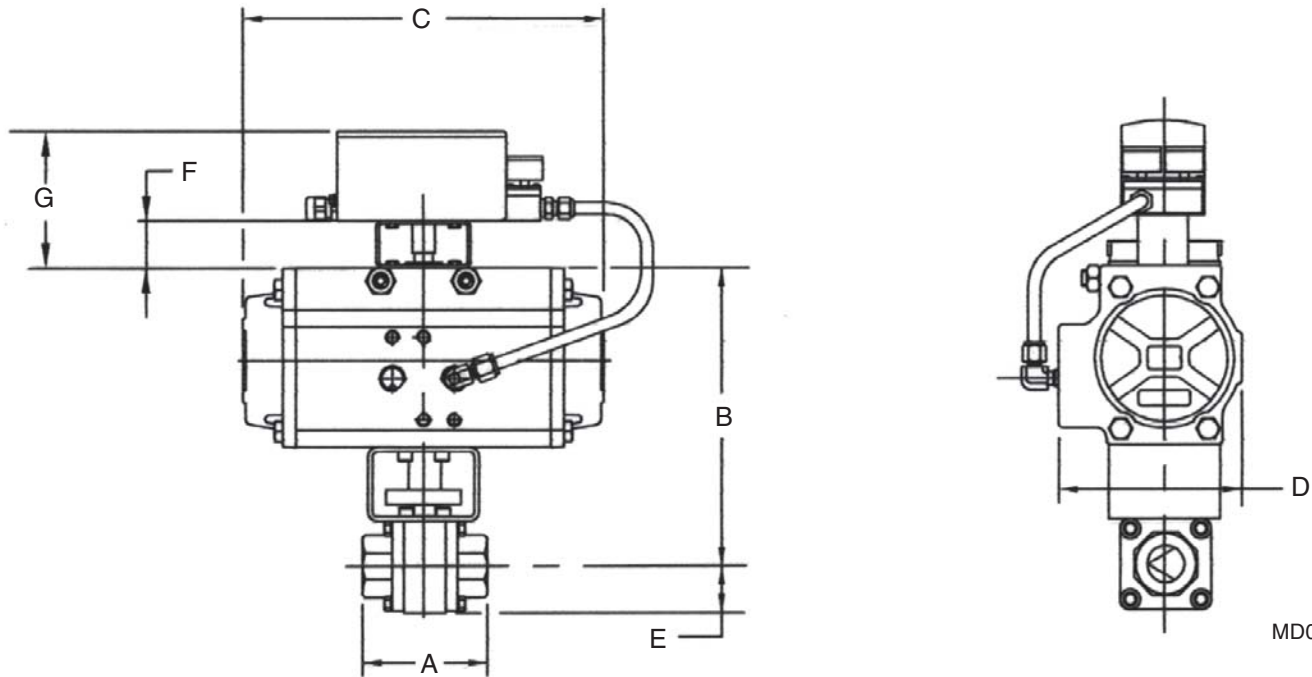

MD03157

CV3000 Full Port with UT Actuator (inches)									
Size	Actuator	Dimensions							Weight (lbs)
		A	B	C	D	E	F	G	
1/4", 3/8"	UT-0-DA	2.95	5.98	5.5	2.8	1.00	1.77	5.57	13.5
	UT-1-SR		6.41	6.4	3.2		1.77	5.57	14.7
1/2"	UT-0-DA	3.15	6.05	5.5	2.8	1.05	1.77	5.57	14.5
	UT-1-SR		6.48	6.4	3.2		1.77	5.57	16.2
3/4"	UT-0-DA	3.35	6.29	5.5	2.8	1.30	1.77	5.57	16.4
	UT-2-SR		7.37	8.2	3.7		1.77	5.57	21.3
1"	UT-1-DA	4.35	6.62	6.4	3.2	1.45	1.77	5.57	19.2
	UT-2.5-SR		7.72	9.4	4.2		1.77	5.57	23.7
△1-1/4"	UT-2-DA	4.75	7.50	8.2	3.7	1.68	1.77	5.57	23.7
	UT-3-SR		8.46	10.7	4.8		1.77	5.57	32.5
△1-1/2"	UT-2-DA	5.55	7.65	8.2	3.7	1.83	1.77	5.57	27.7
	UT-3.5-SR		9.40	12.9	5.4		2.16	5.96	44.4
△ 2"	UT-3.5-DA	5.55	9.48	12.9	5.4	2.62	2.16	5.96	48.5
	UT-5-SR		11.70	20.6	7.4		2.16	5.96	84.4
△2-1/2"	UT-5-DA	6.70	11.20	14.4	7.4	2.95	2.16	5.96	77.6
	UT-6-SR		14.11	22.6	8.6		2.16	5.96	139.4
△ 3"	UT-5-DA	9.20	12.84	20.6	7.4	3.69	2.16	5.96	90.6
	UT-6-SR		14.85	22.6	8.6		2.16	5.96	147.6

△ Differential pressure across valve = 1000 psi (68,9 bar)

Seat material is RPTFE

Actuators in table sized with standard 1.2 service factor

CV3000 Standard Port with UT Actuator (mm)									
Size	Actuator	Dimensions							Weight (kgs)
		A	B	C	D	E	F	G	
DN8, 12	UT-0-DA	74,9	152	140	71	25,4	45	142	6,1
	UT-1-SR		163	163	81		45	142	6,7
DN15	UT-0-DA	80,0	154	140	71	26,7	45	142	6,6
	UT-1-SR		165	163	81		45	142	7,3
DN20	UT-0-DA	85,1	160	140	71	33,0	45	142	7,4
	UT-2-SR		187	208	94		45	142	9,7
DN25	UT-1-DA	110,5	168	163	81	36,8	45	142	8,7
	UT-2.5-SR		196	239	107		45	142	10,8
△DN32	UT-2-DA	120,7	191	208	94	42,7	45	142	10,8
	UT-3-SR		215	272	122		45	142	14,7
△DN40	UT-2-DA	141,0	194	208	94	46,5	45	142	12,6
	UT-3.5-SR		239	328	137		55	151	20,1
△DN50	UT-3.5-DA	141,0	241	328	137	66,5	55	151	22,0
	UT-5-SR		297	523	137		55	151	38,3
△DN65	UT-5-DA	170,2	285	366	188	74,9	55	151	35,2
	UT-6-SR		358	574	218		55	151	63,2
△DN80	UT-5-DA	233,7	326	523	188	93,7	55	151	41,1
	UT-6-SR		377	574	218		55	151	67,4

# Marwin Valve CV3000 Series – Dimensions

## CV3000 Series Standard Port with UT Series Pneumatic Actuator and 2IQPositioner

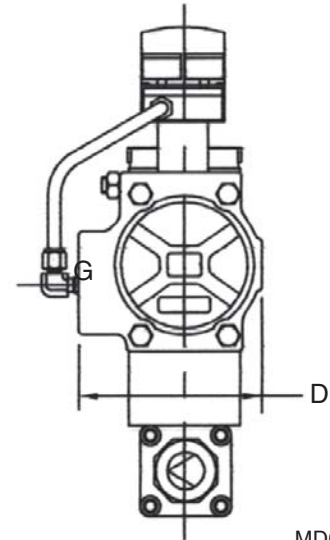
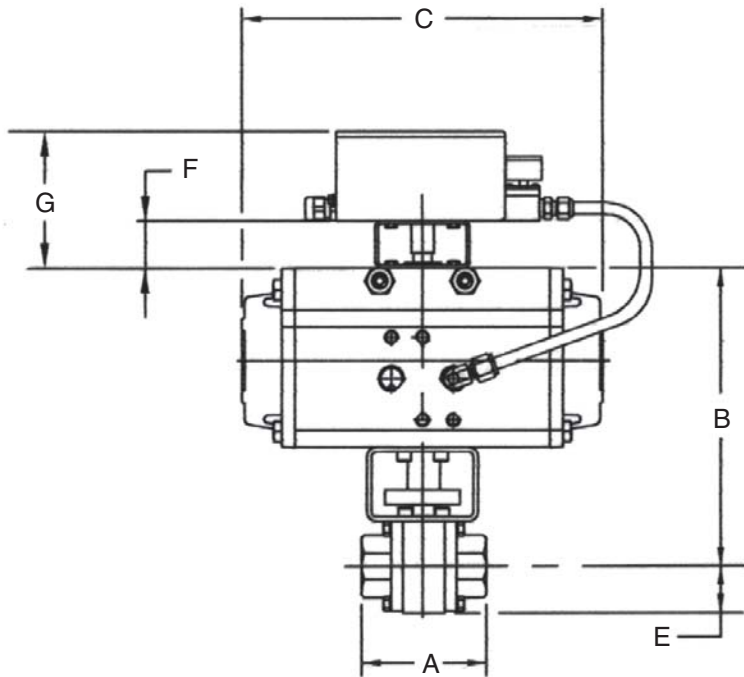

MD03156

CV3000 Standard Port with UT Actuator (inches)									
Size	Actuator	Dimensions							Weight (lbs)
		A	B	C	D	E	F	G	
1/2"	UT-0-DA	2.95	5.98	5.5	2.8	1.00	1.77	5.57	13.5
	UT-1-SR		6.41	6.4	3.2		1.77	5.57	14.7
3/4"	UT-0-DA	3.15	6.05	5.5	2.8	1.05	1.77	5.57	14.5
	UT-1-SR		6.48	6.4	3.2		1.77	5.57	16.2
1"	UT-0-DA	3.35	6.29	5.5	2.8	1.30	1.77	5.57	16.4
	UT-2-SR		7.37	8.2	3.7		1.77	5.57	21.3
1-1/4"	UT-1-DA	4.35	6.62	6.4	3.2	1.45	1.77	5.57	19.2
	UT-2.5-SR		7.72	9.4	4.2		1.77	5.57	23.7
△ 1-1/2"	UT-2-DA	4.75	7.50	8.2	3.7	1.68	1.77	5.57	23.7
	UT-3-SR		8.46	10.7	4.8		1.77	5.57	32.5
△ 2"	UT-2-DA	5.55	7.65	8.2	3.7	1.83	1.77	5.57	27.7
	UT-3.5-SR		9.40	12.9	5.4		2.16	5.96	44.4
△ 2-1/2"	UT-3.5-DA	5.55	9.48	12.9	5.4	2.62	2.16	5.96	48.5
	UT-5-SR		11.70	20.6	7.4		2.16	5.96	84.4
△ 3"	UT-5-DA	6.70	11.20	14.4	7.4	2.95	2.16	5.96	77.6
	UT-6-SR		14.11	22.6	8.6		2.16	5.96	139.4
△ 4"	UT-5-DA	9.20	12.84	20.6	7.4	3.69	2.16	5.96	90.6
	UT-6-SR		14.85	22.6	8.6		2.16	5.96	148.6

CV3000 Standard Port with UT Actuator (mm)									
Size	Actuator	Dimensions							Weight (kgs)
		A	B	C	D	E	F	G	
DN15	UT-0-DA	74,9	152	140	71	25,4	45	142	6,1
	UT-1-SR		163	163	81		45	142	6,7
DN20	UT-0-DA	80,0	154	140	71	26,7	45	142	6,6
	UT-1-SR		165	163	81		45	142	7,3
DN25	UT-0-DA	85,1	160	140	71	33,0	45	142	7,4
	UT-2-SR		187	208	94		45	142	9,7
DN32	UT-1-DA	110,5	168	163	81	36,8	45	142	8,7
	UT-2.5-SR		196	239	107		45	142	10,8
DN40	UT-2-DA	120,7	191	208	94	42,7	45	142	10,8
	UT-3-SR		215	272	122		45	142	14,7
△ DN50	UT-2-DA	141,0	194	208	94	46,5	45	142	12,6
	UT-3.5-SR		239	328	137		55	151	20,1
△ DN65	UT-3.5-DA	141,0	241	328	137	66,5	55	151	22,0
	UT-5-SR		297	523	137		55	151	38,3
△ DN80	UT-5-DA	170,2	285	366	188	74,9	55	151	35,2
	UT-6-SR		358	574	218		55	151	63,2
△ DN100	UT-5-DA	233,7	326	523	188	93,7	55	151	41,1
	UT-6-SR		377	574	218		55	151	67,4

△ Differential pressure across valve = 1000 psi (68,9 bar)

Seat material is RPTFE

Actuators in table sized with standard 1.2 service factor

# Marwin Valve CV3000 Series – Dimensions

## CV3000 Series Full Port with ER Series Electric Actuator

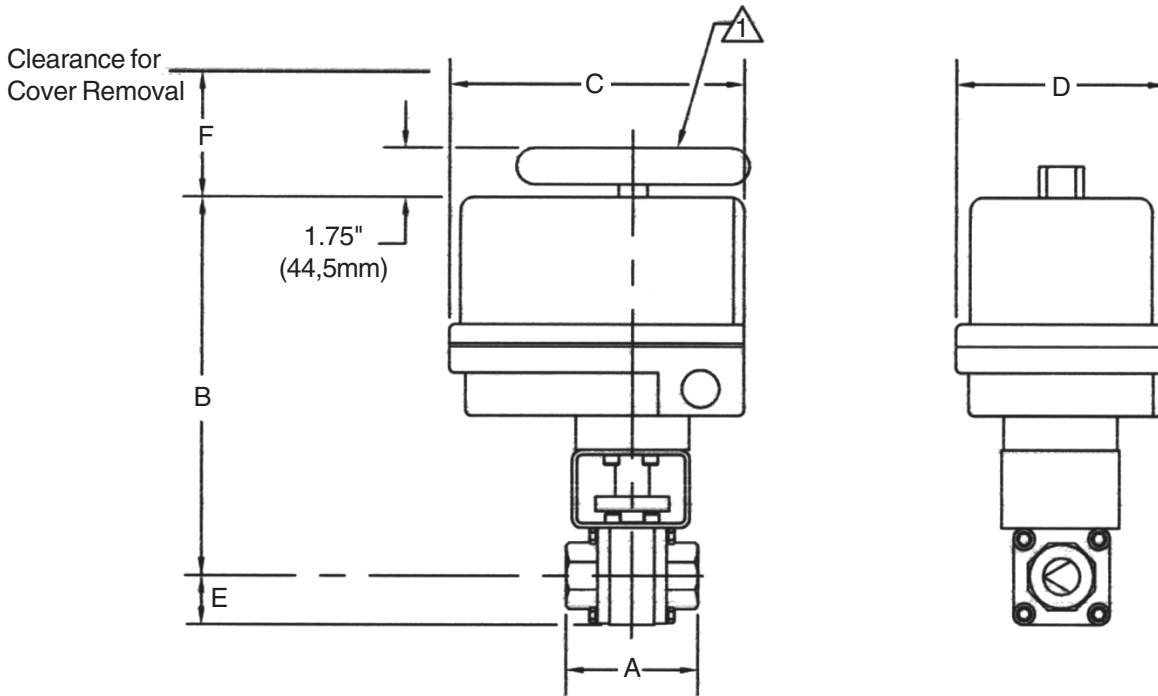

MD03159

CV3000 Full Port with ER Electric Actuator (inches)								
Size	Actuator	Dimensions						Weight (lbs)
		A	B	C	D	E	F	
1/4", 3/8"	ER-1-2-4	2.95	7.74	5.63	4.00	1.00	2.5	12
1/2"	ER-2-5-4	3.15	8.69	6.88	4.25	1.05	2.5	15
3/4"	ER-2-5-4	3.35	8.93	6.88	4.25	1.30	3.0	17
1"	ER-3-5-4	4.35	8.83	6.88	4.25	1.45	3.0	19
△ 1-1/4"	ER-4-10-4	4.75	10.42	7.00	7.00	1.68	3.0	28
△ 1-1/2"	ER-6-15-4	5.55	10.57	7.00	7.00	1.83	3.0	31
△ 2"	ER-15-30-4	5.55	11.04	7.00	7.00	2.62	4.0	40
△ 2-1/2"	ER-38-14-4	6.70	14.01	10.00	10.00	2.95	6.0	65
△ 3"	ER-38-14-4	9.20	14.75	10.00	10.00	3.69	6.0	74

CV3000 Full Port with ER Electric Actuator (mm)								
Size	Actuator	Dimensions						Weight (kgs)
		A	B	C	D	E	F	
DN8, 12	ER-1-2-4	74,9	197	143	102	25,4	64	5,4
DN15	ER-2-5-4	80,0	221	175	108	26,7	64	6,8
DN20	ER-2-5-4	85,1	227	175	108,	33,0	76	7,7
DN25	ER-3-5-4	110,5	224	175	108	36,8	76	8,6
△ DN32	ER-4-10-4	120,7	265	178	178	42,7	76	12,8
△ DN40	ER-6-15-4	141,0	269	178	178	46,5	76	14,1
△ DN50	ER-15-30-4	141,0	280	178	178	66,5	102	18,1
△ DN65	ER-38-14-4	170,2	356	254	254	74,9	152	29,5
△ DN80	ER-38-14-4	233,7	375	254	254	93,7	152	33,6

△ Manual over-ride handwheel provided only on actuators ER-4-10-4, ER-6-15-4, ER-15-30-4 and ER-38-14-4

△ Differential pressure across valve = 1000 psi (68,9 bar)

Seat material is RPTFE

Dimensions given for NEMA 4 enclosure

Actuators in table sized with standard 1.2 service factor

# Marwin Valve CV3000 Series – Dimensions

## CV3000 Series Standard Port with ER Series Electric Actuator

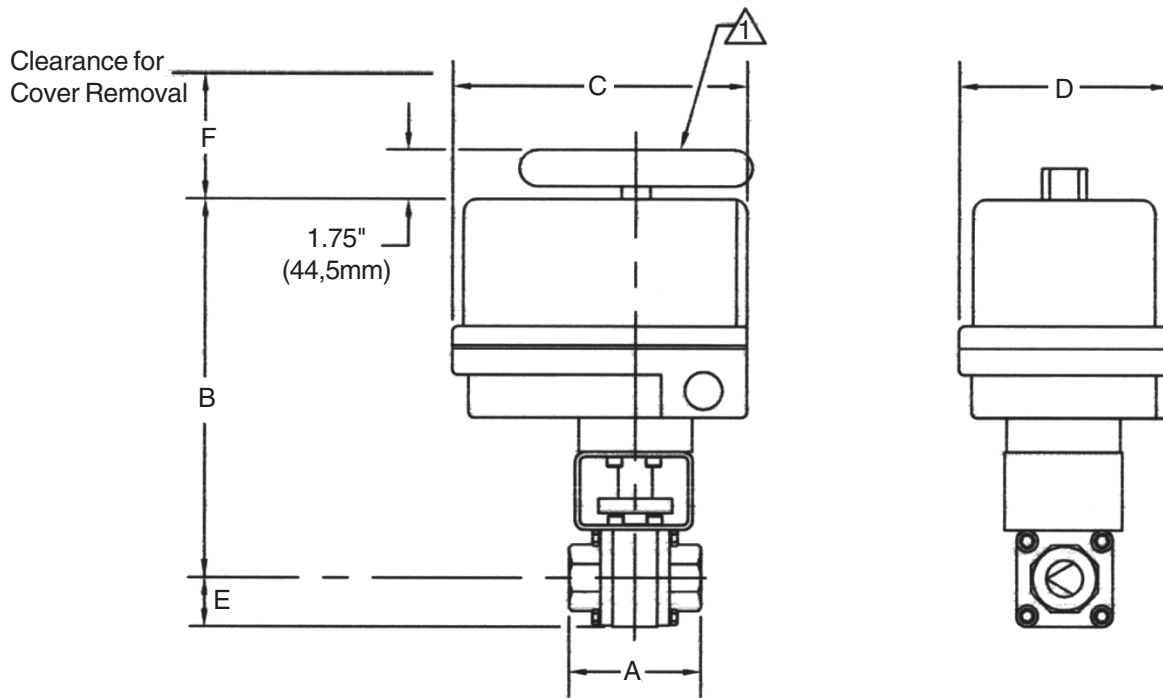

MD03158

CV3000 Standard Port with ER Electric Actuator (inches)								
Size	Actuator	Dimensions						Weight (lbs)
		A	B	C	D	E	F	
1/2"	ER-1-2-4	2.95	7.74	5.63	4.00	1.00	2.5	12
3/4"	ER-2-5-4	3.15	8.69	6.88	4.25	4.05	2.5	15
1"	ER-2-5-4	3.35	8.93	6.88	4.25	1.30	3.0	17
1-1/4"	ER-3-5-4	4.35	8.83	6.88	4.25	1.45	3.0	19
△ 1-1/2"	ER-4-10-4	4.75	10.42	7.00	7.00	1.68	3.0	28
△ 2"	ER-6-15-4	5.55	10.57	7.00	7.00	1.83	3.0	31
△ 2-1/2"	ER-15-30-4	5.55	11.04	7.00	7.00	2.62	4.0	40
△ 3"	ER-38-14-4	6.70	14.01	10.00	10.00	2.95	6.0	65
△ 4"	ER-38-14-4	9.20	14.75	10.00	10.00	3.69	6.0	74

CV3000 Standard Port with ER Electric Actuator (mm)								
Size	Actuator	Dimensions						Weight (kgs)
		A	B	C	D	E	F	
DN15	ER-1-2-4	74,9	197	143	102	25,4	64	5,4
DN20	ER-2-5-4	80,0	221	175	108	26,7	64	6,8
DN25	ER-2-5-4	85,1	227	175	108	33,0	76	7,7
DN32	ER-3-5-4	110,5	224	175	108	36,8	76	8,6
△ DN40	ER-4-10-4	120,7	265	178	178	42,7	76	12,8
△ DN50	ER-6-15-4	141,0	269	178	178	46,5	76	14,1
△ DN65	ER-15-30-4	141,0	280	178	178	66,5	102	18,1
△ DN80	ER-38-14-4	170,2	356	254	254	74,9	152	29,5
△ DN100	ER-38-14-4	233,7	375	254	254	93,7	152	33,6

△ Manual over-ride handwheel provided only on actuators ER-4-10-4, ER-6-15-4, ER-15-30-4 and ER-38-14-4

△ Differential pressure across valve = 1000 psi (68,9 bar)

Seat material is RPTFE

Dimensions given for NEMA 4 enclosure

Actuators in table sized with standard 1.2 service factor

# Marwin Valve CV3000 Series – Material Specifications

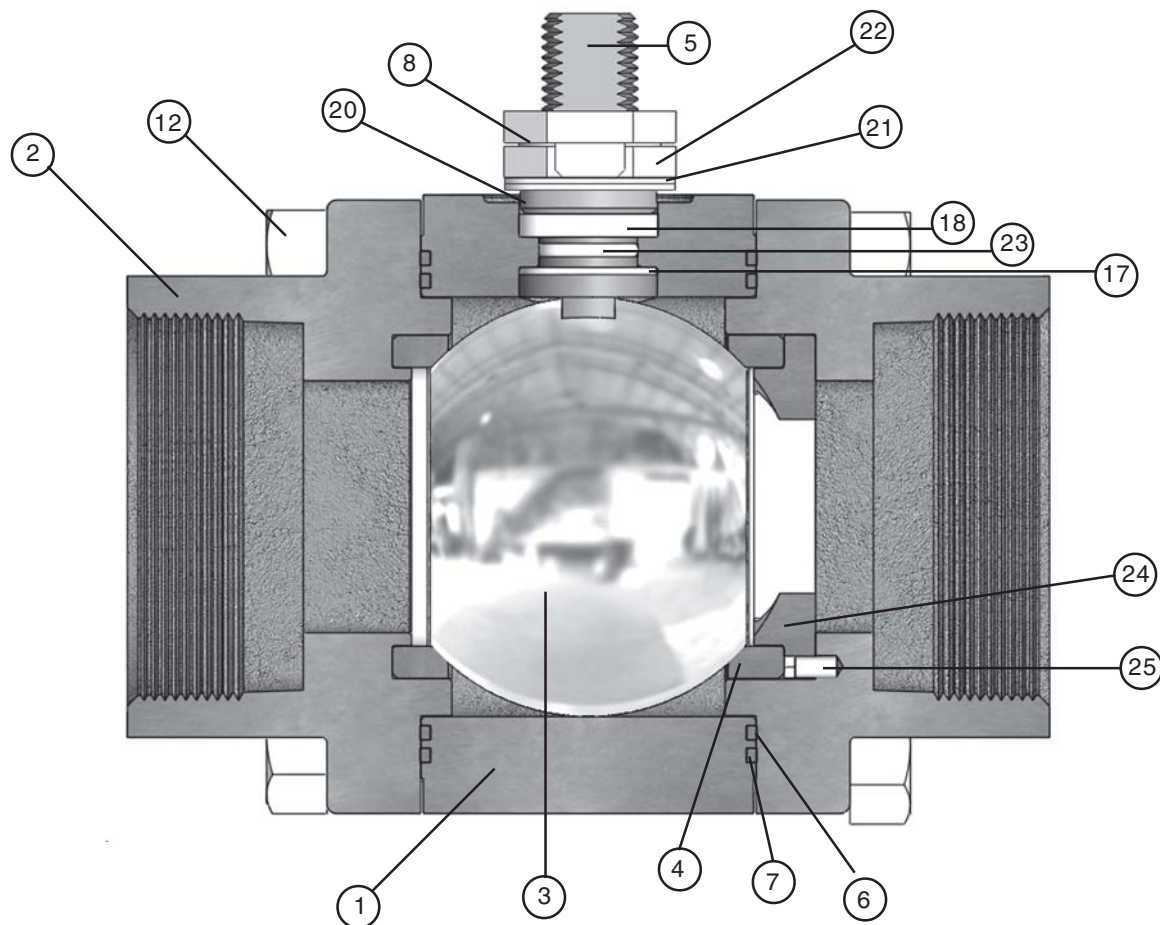

ART0770

Item	Part	Qty	SS	CS
1	Body	1	A351 CF8M	A216 WCB
2	End Cap	2	A351 CF3M	A216 WCB
3	Ball	1	AISI 316 SS	AISI 316 SS
4	Seat	2	CRPTFE	CRPTFE
5	Stem	1	A479 S31600	A479 S31600
6	Body Seal	2	CRPTFE	CRPTFE
7	Secondary Body Seal	2	Non-Asbestos	Non-Asbestos
8	Lock Washer	1	SS	SS
9	Anti-Static Spring (not shown)	1	AISI 316 SS	AISI 316 SS
12	Bolt, Body	8	A193 B8 C11	A193 B7
17	Thrust Washer	1	CRPTFE	CRPTFE
18	Packing	1	PTFE	PTFE
20	Gland Bushing	1	AISI 316 SS	AISI 316 SS
21	Belleville Washer	2	17-7PH SS	17-7PH SS
22	Nut, Stem	2	AISI 316 SS	AISI 316 SS
23	O-Ring, Stem	1	Viton	Viton
24	Characterized Insert	1	A479 S31600	A479 S31600
25	Index Pin	1	A479 S31600	A479 S31600

# Marwin Valve CV3000 Series – Technical Information

Tehchnical Information						
CV3000 CV (Max Round Port)			Recommended Actuator Torque (in/lbs) (Based on 2x factor for Control Applications)			
Valve Size		Cv Max				
Full Port	Standard Port	Round Port	PTFE	RPTFE	Delrin®	PEEK
1/4"	—	8	—	—	—	—
3/8"	1/2"	8	144	144	180	528
1/2"	3/4"	15	144	192	228	768
3/4"	1"	34	216	240	408	1488
1"	1-1/4"	45	408	480	408	1728
1-1/4"	1-1/2"	78	456	576	468	2064
1-1/2"	2"	135	480	672	528	2400
2"	2-1/2"	250	864	1224	876	2880
2-1/2"	3"	445	1800	3360	consult factory	consult factory
3"	4"	680	1920	4320	consult factory	consult factory

Refer to 3000 Series bulletin 3000/MS3000 for pressure-temperature ratings and additional dimensional drawings.

## Standard Characterized Seat Inserts



Full Round



Slot



30° Angle



60° Angle



90° Angle

# Marwin Valve CV3000 Series – Flow Coefficient

## CV vs Travel (Full Port Valve)

Percent of Travel (Degree of Rotation)													
Size	Type	Characterized Insert	0% (0°)	10% (9°)	20% (18°)	30% (27°)	40% (36°)	50% (45°)	60% (54°)	70% (63°)	80% (72°)	90% (81°)	100% (90°)
0.25F	1/32	SA	0.00	0.00	0.033	0.074	0.12	0.16	0.20	0.24	0.28	0.32	0.40
	1/16" Slot	S1	0.00	0.00	0.07	0.20	0.33	0.46	0.60	0.73	0.86	0.99	1.10
	30°V	A1	0.00	0.00	0.10	0.20	0.34	0.55	0.83	1.11	1.59	2.08	2.50
	60°V	A2	0.00	0.00	0.12	0.33	0.49	0.84	1.35	1.95	3.10	4.37	5.92
	Round Port	R1	0.00	0.00	0.29	0.46	0.70	1.09	1.76	2.60	2.24	6.40	8.00
0.38F	1/32	SA	0.00	0.00	0.033	0.074	0.12	0.16	0.20	0.24	0.28	0.32	0.40
	1/16" Slot	S1	0.00	0.00	0.07	0.20	0.33	0.46	0.60	0.73	0.86	0.99	1.10
	30°V	A1	0.00	0.00	0.10	0.20	0.34	0.55	0.83	1.11	1.59	2.08	2.50
	60°V	A2	0.00	0.00	0.12	0.33	0.49	0.84	1.35	1.95	3.10	4.37	5.92
	Round Port	R1	0.00	0.00	0.29	0.46	0.70	1.09	1.76	2.60	2.24	6.40	8.00
0.50F	1/16" Slot	S1	0.00	0.00	0.06	0.24	0.40	0.56	0.73	0.90	1.00	1.20	1.30
	1/8" Slot	S3	0.00	0.00	0.14	0.39	0.65	0.90	1.20	1.40	1.70	1.90	2.90
	30°V	A1	0.00	0.00	0.11	0.24	0.41	0.67	1.00	1.40	1.90	2.60	3.00
	60°V	A2	0.00	0.00	0.13	0.36	0.55	1.00	1.50	2.30	3.60	5.00	6.70
	Round Port	R1	0.00	0.00	0.43	0.70	1.10	1.60	2.60	4.00	6.40	9.60	12.00
0.75F	1/16" Slot	S1	0.00	0.00	0.10	0.40	0.67	0.94	1.20	1.50	1.70	1.90	2.10
	3/16" Slot	S4	0.00	0.00	0.22	0.82	1.40	1.90	2.50	3.10	3.50	4.00	4.30
	30°V	A1	0.00	0.00	0.21	0.56	1.00	1.60	2.40	3.40	4.60	6.20	7.30
	60°V	A2	0.00	0.00	0.30	0.78	1.20	2.30	3.60	5.30	8.30	11.60	15.50
	90°V	A4	0.00	0.00	0.48	1.20	2.30	3.50	5.40	7.70	10.80	12.10	19.70
Round Port	R1	0.00	0.00	1.20	1.90	2.80	4.30	7.00	10.50	17.00	26.00	32.00	
1.00F	3/16" Slot	S4	0.00	0.00	0.38	1.40	2.40	3.40	4.40	5.40	6.20	6.90	7.50
	30°V	A1	0.00	0.00	0.39	1.00	1.80	2.90	4.40	6.40	8.60	11.40	13.50
	60°V	A2	0.00	0.00	0.48	1.30	2.00	3.70	5.80	8.50	13.40	18.70	25.00
	90°V	A3	0.00	0.00	0.78	2.00	3.70	5.70	8.80	12.50	17.50	19.70	32.00
	Round Port	R1	0.00	0.00	1.80	3.00	4.40	6.70	10.90	16.40	26.60	40.60	50.00
1.25F	3/16" Slot	S4	0.00	0.00	0.47	1.80	3.00	4.20	5.40	6.80	7.70	8.60	9.40
	30°V	A1	0.00	0.00	0.41	1.20	2.10	3.50	5.20	7.60	10.30	13.70	16.30
	60°V	A2	0.00	0.00	0.57	1.70	3.00	5.60	9.10	13.20	19.80	28.40	37.50
	90°V	A3	0.00	0.00	1.00	2.80	4.50	8.10	13.40	19.70	30.90	47.10	71.70
	Round Port	R1	0.00	0.00	3.00	4.8	7.20	11.00	18.00	27.00	44.00	65.50	82.00
1.50F	1/4" Slot	S5	0.00	0.00	0.75	2.90	4.80	6.80	8.70	10.80	12.30	13.80	15.00
	30°V	A1	0.00	0.00	0.55	1.70	3.40	5.70	8.30	12.10	16.60	22.20	26.50
	60°V	A2	0.00	0.00	0.70	2.60	4.90	9.30	15.50	22.20	32.10	47.20	61.60
	90°V	A3	0.00	0.00	0.88	3.30	6.10	11.70	19.40	27.50	40.10	59.00	77.00
	Round Port	R1	0.00	0.00	4.30	7.00	10.50	16.20	26.40	39.60	64.00	96.00	120.00
2.00F	3/8" Slot	S6	0.00	0.00	1.00	3.80	6.40	9.00	11.60	14.40	16.40	18.40	20.00
	30°V	A1	0.00	0.00	1.00	3.20	6.40	10.60	15.40	22.60	31.00	41.50	49.50
	60°V	A2	0.00	0.00	1.00	3.80	7.10	13.50	22.50	32.20	46.60	68.50	89.40
	90°V	A3	0.00	0.00	1.90	7.10	13.10	25.00	41.60	58.90	85.90	126.40	165.00
	Round Port	R1	0.00	0.00	9.40	15.10	22.80	35.10	57.20	85.80	138.70	208.00	260.00
2.50F	7/16" Slot	S7	0.00	0.00	1.20	4.60	7.80	11.00	14.20	17.60	20.00	22.40	24.40
	30°V	A1	0.00	0.00	0.75	2.70	6.00	10.20	16.90	24.50	33.90	44.80	54.20
	60°V	A2	0.00	0.00	1.00	4.30	10.10	18.60	29.40	46.30	67.20	94.40	124.60
	90°V	A3	0.00	0.00	1.20	8.00	14.00	26.00	44.00	67.00	102.00	151.00	230.00
	Round Port	R1	0.00	0.00	12.60	20.20	31.10	47.40	77.80	115.00	187.00	280.00	350.00
3.00F	1/2" Slot	S8	0.00	0.00	2.50	9.30	15.70	22.10	28.40	35.3	40.20	45.10	49.00
	30°V	A1	0.00	0.00	0.90	3.60	8.50	16.10	26.80	40.20	56.60	72.50	90.00
	60°V	A2	0.00	0.00	1.20	5.70	15.40	28.80	48.60	73.40	107.00	150.70	200.00
	90°V	A3	0.00	0.00	2.00	9.00	23.00	42.00	72.00	110.00	167.00	250.00	380.00
	Round Port	R1	0.00	0.00	26.00	42.10	63.10	97.20	159.00	238.00	385.00	575.00	720.00

CV is defined as flow of liquid in gallons per minute through a valve with a pressure drop of 1 psi across the valve.  
Recommended usage is between 25% and 85% travel.

# Marwin Valve CV3000 Series – Flow Coefficient

## CV vs Travel (Standard Port Valve)

Percent of Travel (Degree of Rotation)													
Size	Type	Characterized Insert	0% (0°)	10% (9°)	20% (18°)	30% (27°)	40% (36°)	50% (45°)	60% (54°)	70% (63°)	80% (72°)	90% (81°)	100% (90°)
0.50R	1/64" Slot	SB	0.00	0.00	0.01	0.03	0.40	0.06	0.08	0.09	0.11	0.12	0.14
	1/32" Slot	SA	0.00	0.00	0.03	0.07	0.12	0.16	0.20	0.24	0.28	0.32	0.36
	1/16" Slot	S1	0.00	0.00	0.07	0.20	0.33	0.46	0.60	0.73	0.86	1.00	1.10
	30°V	A1	0.00	0.00	0.11	0.24	0.36	0.56	0.84	1.10	1.60	2.10	2.60
	60°V	A2	0.00	0.00	0.12	0.33	0.60	0.84	1.40	2.00	3.10	4.40	5.90
	Round Port	R1	0.00	0.00	0.29	0.46	0.70	1.10	1.80	2.60	4.30	6.40	8.00
0.75R	1/16" Slot	S1	0.00	0.00	0.06	0.24	0.40	0.56	0.73	0.90	1.00	1.20	1.30
	1/8" Slot	S3	0.00	0.00	0.14	0.39	0.65	0.90	1.20	1.40	1.70	1.90	2.90
	30°V	A1	0.00	0.00	0.11	0.24	0.41	0.67	1.00	1.40	1.90	2.60	3.00
	60°V	A2	0.00	0.00	0.13	0.36	0.55	1.00	1.50	2.30	3.60	5.00	6.70
	Round Port	R1	0.00	0.00	0.43	0.70	1.10	1.60	2.60	4.00	6.40	9.60	12.00
1.00R	1/16" Slot	S1	0.00	0.00	0.10	0.40	0.67	0.94	1.20	1.50	1.70	1.90	2.10
	3/16" Slot	S4	0.00	0.00	0.22	0.82	1.40	1.90	2.50	3.10	3.50	4.00	4.30
	30°V	A1	0.00	0.00	0.21	0.56	1.00	1.60	2.40	3.40	4.60	6.20	7.30
	60°V	A2	0.00	0.00	0.30	0.78	1.20	2.30	3.60	5.30	8.30	11.60	15.50
	90°V	A3	0.00	0.00	0.48	1.20	2.30	3.50	5.40	7.70	10.80	12.10	19.70
	Round Port	R1	0.00	0.00	1.20	1.90	2.80	4.30	7.00	10.50	17.00	26.00	32.00
1.25R	3/16" Slot	S4	0.00	0.00	0.38	1.40	2.40	3.40	4.40	5.40	6.20	6.90	7.50
	30°V	A1	0.00	0.00	0.39	1.00	1.80	2.90	4.40	6.40	8.60	11.40	13.50
	60°V	A2	0.00	0.00	0.48	1.30	2.00	3.70	5.80	8.50	13.40	18.70	25.00
	90°V	A3	0.00	0.00	0.78	2.00	3.70	5.70	8.80	12.50	17.50	19.70	32.00
	Round Port	R1	0.00	0.00	1.80	3.00	4.40	6.70	10.90	16.40	26.60	40.60	50.00
1.50	3/16" Slot	S4	0.00	0.00	0.47	1.80	3.00	4.20	5.40	6.80	7.70	8.60	9.40
	30°V	A1	0.00	0.00	0.41	1.20	2.10	3.50	5.20	7.60	10.30	13.70	16.30
	60°V	A2	0.00	0.00	0.57	1.70	3.00	5.60	9.10	13.20	19.80	28.40	37.50
	90°V	A3	0.00	0.00	1.00	2.80	4.50	8.10	13.40	19.70	30.90	47.10	71.70
	Round Port	R1	0.00	0.00	3.00	4.8	7.20	11.00	18.00	27.00	44.00	65.50	82.00
2.00R	1/4" Slot	S5	0.00	0.00	0.75	2.90	4.80	6.80	8.70	10.80	12.30	13.80	15.00
	30°V	A1	0.00	0.00	0.55	1.70	3.40	5.70	8.30	12.10	16.60	22.20	26.50
	60°V	A2	0.00	0.00	0.70	2.60	4.90	9.30	15.50	22.20	32.10	47.20	61.60
	90°V	A3	0.00	0.00	0.88	3.30	6.10	11.70	19.40	27.50	40.10	59.00	77.00
	Round Port	R1	0.00	0.00	4.30	7.00	10.50	16.20	26.40	39.60	64.00	96.00	120.00
2.50R	3/8" Slot	S6	0.00	0.00	1.00	3.80	6.40	9.00	11.60	14.40	16.40	18.40	20.00
	30°V	A1	0.00	0.00	1.00	3.20	6.40	10.60	15.40	22.60	31.00	41.50	49.50
	60°V	A2	0.00	0.00	1.00	3.80	7.10	13.50	22.50	32.20	46.60	68.50	89.40
	90°V	A3	0.00	0.00	1.90	7.10	13.10	25.00	41.60	58.90	85.90	126.40	165.00
	Round Port	R1	0.00	0.00	9.40	15.10	22.80	35.10	57.20	85.80	138.70	208.00	260.00
3.00R	7/16" Slot	S7	0.00	0.00	1.20	4.60	7.80	11.00	14.20	17.60	20.00	22.40	24.40
	30°V	A1	0.00	0.00	0.75	2.70	6.00	10.20	16.90	24.50	33.90	44.80	54.20
	60°V	A2	0.00	0.00	1.00	4.30	10.10	18.60	29.40	46.30	67.20	94.40	124.60
	90°V	A3	0.00	0.00	1.20	8.00	14.00	26.00	44.00	67.00	102.00	151.00	230.00
	Round Port	R1	0.00	0.00	12.60	20.20	31.10	47.40	77.80	115.00	187.00	280.00	350.00
4.00R	1/2" Slot	S8	0.00	0.00	2.50	9.30	15.70	22.10	28.40	35.3	40.20	45.10	49.00
	30°V	A1	0.00	0.00	0.90	3.60	8.50	16.10	26.80	40.20	56.60	72.50	90.00
	60°V	A2	0.00	0.00	1.20	5.70	15.40	28.80	48.60	73.40	107.00	150.70	200.00
	90°V	A3	0.00	0.00	2.00	9.00	23.00	42.00	72.00	110.00	167.00	250.00	380.00
	Round Port	R1	0.00	0.00	26.00	42.10	63.10	97.20	159.00	238.00	385.00	575.00	720.00

CV is defined as flow of liquid in gallons per minute through a valve with a pressure drop of 1 psi across the valve. Recommended usage is between 25% and 85% travel.

## CV3000 Series Ordering Schematic

Prefix	Series	Size	Body Material	1	2	3	4	5	6	7	8	9	10			
CV	3000F	—	100	—	S6	/	S	E	A	1	D	L	T	V	H	L

Prefix	
CV	Control Valve

Series	
3000F	Full Port
3000R	Standard Port

Size	
025	1/4" (DN8) (Full Port Only)
038	3/8" (DN12) (Full Port Only)
050	1/2" (DN15)
075	3/4" (DN20)
100	1" (DN25)
125	1-1/4" (DN32)
150	1-1/2" (DN40)
200	2" (DN50)
250	2-1/2" (DN65)
300	3" (DN80)
400	4" (DN100) (Standard Port Only)

Body Material	
CS	Carbon Steel WCB
S6	Stainless Steel CF8M
ZZ	**Other Special Alloy

1&2	End Connections
PT	FNPT
SW	FSW
SE	FSW Extended
F1	150# FE
F3	300# FE
F6	600# FE
E4	BWE Extended Sch 40
E8	BWE Extended Sch 80
ZZ	Non-Standard

\* Refer to flow coefficient chart. Page 10 and 11 for slot size No. "X"  
 \*\* Refer to 3000 Series bulletin and specify  
 \*\*\* Specify reverse rotating actuator for automated fail open CV 3000 valves

3&4	Characterized Insert / Open/Trim Material
A1	30 Degree V/316 SS
A2	60 Degree V/ 316 SS
A3	90 Degree V/ 316 SS
R1	Full Round / 316 SS
*SX	Slot / 316 SS
ZZ	**Other Special Alloy

5&6	Seat/Body Seals/Thrust Washer
TF	PTFE / PTFE / PTFE
RT	RPTFE / RPTFE / RPTFE
PA	PFA / PFA / PFA
SF	C-RPTFE / C-RPTFE / C-RPTFE
DL	Delrin / Viton / RPTFE
PK	PEEK / Viton / PEEK
CP	C-PEEK / Graphite / PEEK
UM	UHMWPE / Viton / UHMWPE
ZZ	Non-Standard

7&8	Packing/Stem-O-Ring
TV	PTFE / Viton
TE	PTFE / EPDM
GV	Grafoil / Viton
GE	Grafoil / EPDM
UV	UHMWPE / Viton
UE	UHMWPE / EPDM
ZZ	Non-Standard

9&10	Handle & Gear Operator
NN	None
HL	Handle Lever
HD	Handle Lever with Locking Device
GO	Gear Operator
HT	10 Position Handle 1/4"F ~ 2-1/2"R only
ZZ	***Non-Standard

Note: ZZ non-standard options must be specified on purchase order or inquiry.



**Marwin Valve, a division of Richards Industries**  
 3170 Wasson Road • Cincinnati, OH 45209  
 513-533-5600 • 800-543-7311 • 513-871-0105 (f)  
 marwin@richardsind.com • www.marwinvalve.com